



Series 2 digital force gauges are designed for basic tension and compression force testing applications up to 500 lbF (2,500 N). Peak tension and compression readings are reliably captured via the gauges' $\pm 0.5\%$ accuracy and 500 Hz sampling rate. A backlit graphic LCD displays the current, peak tension, or peak compression reading. USB output is provided for data collection purposes.

The gauges are overload protected to 200% of capacity. An ergonomic, reversible aluminum housing allows for hand held use or fixture mounting, rugged enough for applications in both production and laboratory environments. Series 2 gauges are directly compatible with Mark-10 test stands and grips.



USB port for data communication



► Shown with an ES20 test stand and G1061 wedge grips

Features

- Calculates peak tension and compression values
- USB data output of continuous or individual data points
- 3 selectable units of measurement
- Ultra-compact, ergonomic housing
- Configurable default measurement unit and mode
- 500 Hz sampling rate
- Large, backlit graphic display with auto-dimming
- Powered by rechargeable battery or AC adapter
- Reversible housing for alternate load cell orientation

Display Indicators



Tension / compression indicator

Battery / AC indicator

Current reading

Unit of measurement (lbF, kgF, N)

Measurement mode (real-time, peak compression, peak tension)

Optional Items

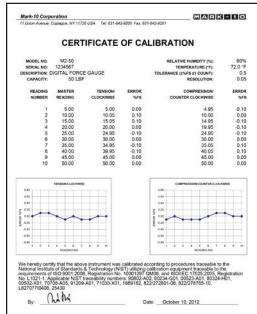

Certificate of calibration

Includes 10 data points in the tension and compression directions. NIST-traceable.

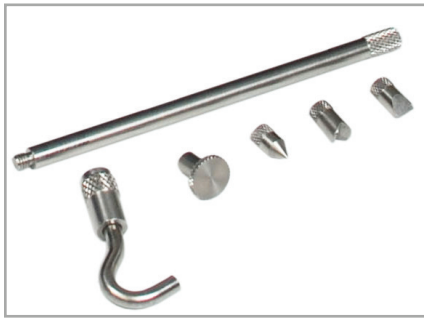

Attachments

Available individually or as kits. Select from hooks, flats, cones, chisels, v-grooves, and extension rods.

Ordering Information - Gauges

Model	Capacity x Resolution		
	lbF	kgF	N
M2-2	2 x 0.002	1 x 0.001	10 x 0.01
M2-5	5 x 0.005	2.5 x 0.002	25 x 0.02
M2-10	10 x 0.01	5 x 0.005	50 x 0.05
M2-20	20 x 0.02	10 x 0.01	100 x 0.1
M2-50	50 x 0.05	25 x 0.02	250 x 0.2
M2-100	100 x 0.1	50 x 0.05	500 x 0.5
M2-200	200 x 0.2	100 x 0.1	1000 x 1
M2-500	500 x 0.5	250 x 0.2	2500 x 2

In The Box



Series 2 force gauges are shipped as shown above, and includes the following accessories:

- (1) Carrying case
- (1) AC adapter
- (1) USB cable
- (1) Certificate of conformance

Ordering Information - Optional Items

For All Series 2 Gauges	
CERT	Certificate of calibration with data

For M2-2 - M2-100 Gauges	
G1038	Medium hook, #10-32M (requires G1039)
G1039	Coupling, #10-32F/F
G1029	Flat head, #10-32F
G1026	Cone, #10-32F
G1025	Chisel point, #10-32F
G1027	V-groove, #10-32F
G1024	Extension rod, 5", #10-32F
23-1031-2	Attachments kit (qty. 1 of G1038 through G1024)

For M2-200 - M2-500 Gauges	
G1035	Large hook, 5/16-18M (requires G1037)
G1037	Coupling, 5/16-18F/F
G1036	Flat head, 5/16-18F
G1033	Cone, 5/16-18F
G1032	Chisel point, 5/16-18F
G1034	V-groove, 5/16-18F
G1031	Extension rod, 5", 5/16-18F
23-1031-3	Attachments kit (qty. 1 ea. of G1035 through G1031)

Specifications

Accuracy:	±0.5% of full scale
Sampling Rate:	500 Hz
Power:	AC adapter: 100-240VAC, 50-60 Hz, 0.3 A Battery: Rechargeable 8.4V NiMH Low battery indicator appears when battery level is low, and gauge powers off automatically when power reaches critical stage.
Battery life:	Backlight on: Up to 7 hours of continuous use Backlight off: Up to 24 hours of continuous use
USB output:	Configurable to 115,200 baud.
Safe overload:	200% of full scale (display shows "OVER" at 110% and above)
Weight:	M2-2 - M2-100: 0.7 lb [0.33 kg] M2-200 - M2-500: 0.9 lb [0.41 kg]
Environmental requirements:	40 - 100°F, max. 96% humidity, non-condensing
Warranty:	3 years (see individual statement for further details)

Dimensions in [mm]

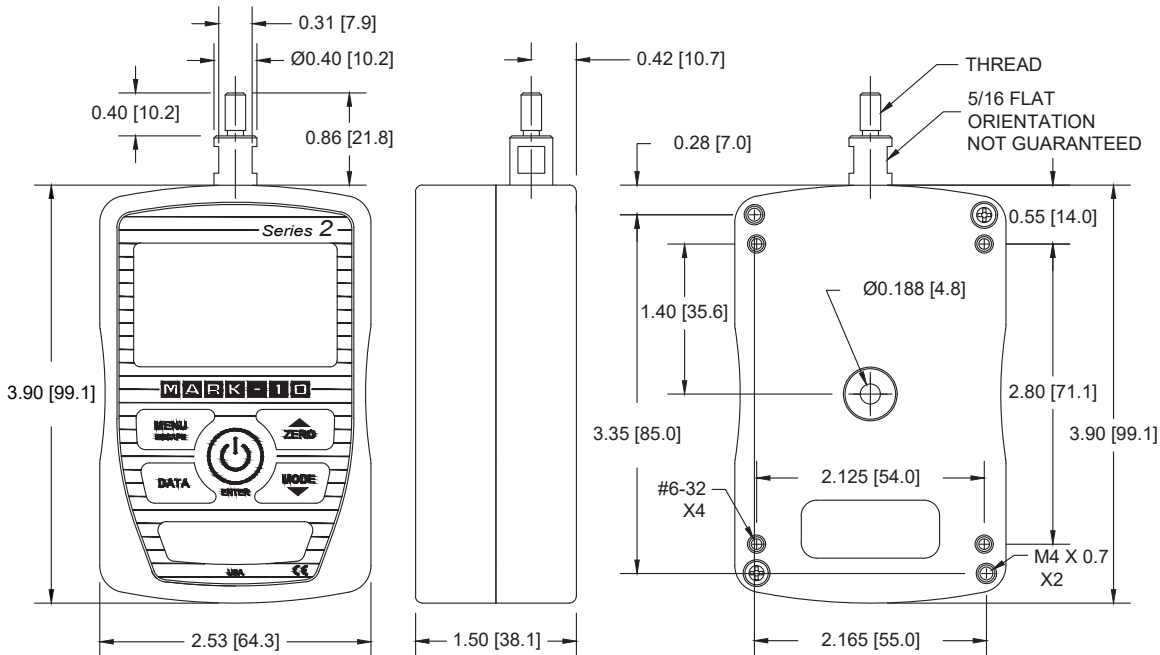

	Thread
M2-2 - M2-100	#10-32 UNF
M2-200 - M2-500	5/16-18 UNC